

Each Norwell light fixture has a mounting bar or plate to secure it to the electrical junction box. No matter what type of mounting bar/plate your fixture uses, installation requires three basic steps.

1. Attach the mounting bar/plate to the electrical junction box.
2. Connect the electrical wires from the junction box to the electrical wires from the fixture.
(Black to Black, White to White and Green to Ground)
3. Secure the fixture to the mounting bar/plate.

Norwell Lighting INSTRUCTIONS

1242

INSTALLATION OF FIXTURE

- 1) ATTACH MOUNTING PLATE TO J-BOX WITH 2 SCREWS.
- 2) CONNECT THE ELECTRICAL WIRES FROM YOUR J-BOX TO THE WIRES FROM THE FIXTURE USING WIRE NUTS. (BLACK TO BLACK, WHITE TO WHITE, GREEN TO GROUND)
- 3) ATTACH THE FIXTURE TO THE MOUNTING PLATE, USING THE (3) MOUNTING SCREWS. ENSURE THE FIXTURE IS SNUG TO THE CEILING.
- 4) SLIDE THE GLASS OVER THE SOCKET AND LOCK IN PLACE WITH THE LOCK-UP RING
- 5) LAMP FIXTURE WITH THE REQUIRED NUMBER OF LAMPS AND WATTAGE PER FIXTURE.

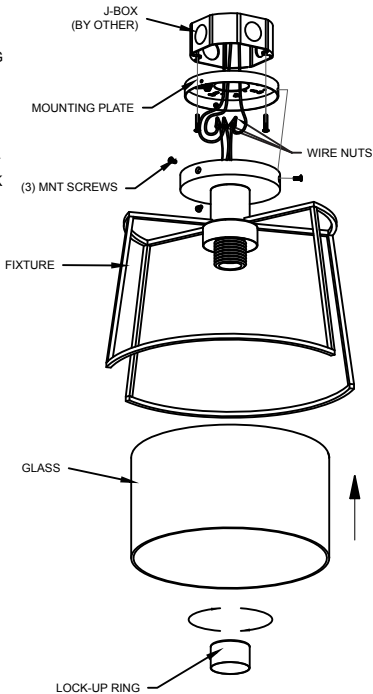

- Be sure to read and understand all instruction sheets completely before beginning assembly or installation.
- Be sure the power is turned off by either by removing the fuse or closing the circuit breaker.
- All assembly and installation work must be in accordance with National, State and Local electrical codes. We strongly advise using a licensed electrician.
- Be aware that the weight of some fixtures may exceed the strength rating of the 4" electrical junction box or other such hardware at your site. In all cases, it is the responsibility of the contractor to properly secure the fixture to the structure, and to provide adequate support for the fixture.
- Due to constant production improvements, details of the design, material or finish may change in any way that will not significantly alter installed appearance or reduce function or performance.